

ACOUSTIC DOOR

AP-30-PAN-E

TECH SHEET—AP-30-PAN-E

Issue: 13-12-04

60 minute fire rated 30 Rw acoustic / smoke / fire door PAIR

DESCRIPTION

Pyropanel AP-30-PAN-E is a 30 Rw 1 hour fire rated 48mm acoustic door PAIR that utilises a Raven Products bottom seal, a Pyropanel Euroseal concealed perimeter seal, and a Pyropanel rebated rubber meeting stile.

APPLICATIONS

Ideal for unit entry applications or anywhere that requires 60 minutes of fire resistance and an acoustic rating of 30 Rw in a pair configuration.

FEATURES

Acoustic Rating

- 30 Rw (30 STC)

Test Certificate number

- TL373(n)

Fire Resistance

- FRL -/60/30

Door Configuration

- Single acting pair configuration hung in a steel or timber frame.

Perimeter Seal

- Pyropanel Euroseal® concealed smoke / acoustic seal

Bottom Seal

- Raven RP99

Meeting Stile

- Pyropanel rubber rebated meeting stile

Thickness

- 48mm (Nominal)

Size

- Maximum Size (overall) - 2400 high x 2040 wide

Hinges

- Minimum 3 steel hinges

Frame

- Pyropanel KDHW timber or packed pressed metal frame

Finish

- MDF as standard

OPTIONAL EXTRAS

- Pre-hung in steel or timber frame
- Ply, Veneer, Steel or Laminate facings
- Vision panels - 300 x 200 or 250 x 250mm.
- Kick Panels of 1.2mm Stainless Steel to selected height
- Meets the BCA requirement for a smoke door.

INSTALLATION

Door frame must be tightly sealed against wall structure using Pyropanel Multiflex or approved alternative fire and acoustic sealant. Metal door frames will require packing with Pyropanel FR board, Fire rated plaster, concrete or mortar to achieve desired acoustic rating.

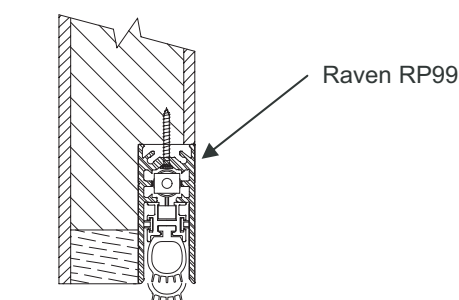
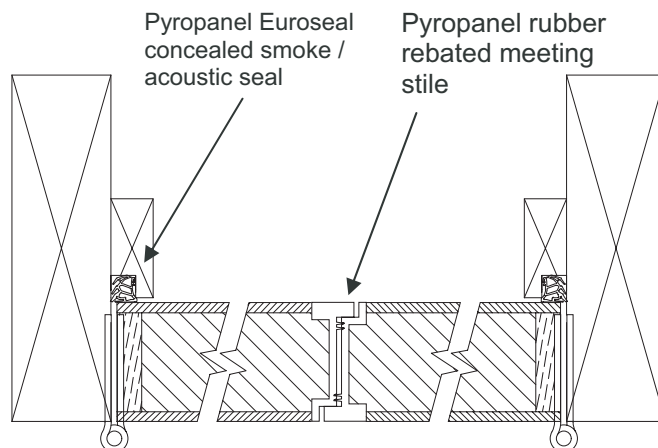

HOW TO SPECIFY

"Door to be a Pyropanel AP-30-PAN-E acoustic door pair with -/60/30 FRL, installed into a Pyropanel Fire rated timber / packed metal* door frame"*

* denotes example—delete, change or specify as required



UNITED DOORMAKERS

Melba Industrial Park, Factory 2,
122-124 Beresford Road, Lilydale,
Victoria 3140, Australia.

T: +61 3 9735 3911 F: +61 3 9735 5411

W: www.udm.com.au E: sales@udm.com.au

Part of the

PYROPANEL

Group