

# ACOUSTIC DOOR

## AS-28-PAN(ii)

### TECH SHEET—AS-28-PAN(ii)

Issue: 13-12-04

**60 minute fire rated 28 Rw single acoustic / smoke / fire door**

### DESCRIPTION

Pyropanel AS-28-PAN(ii) is a 28 Rw, 1 hour fire rated 48mm single leaf acoustic door that utilises a Raven Products RP47 perimeter seal and a RP99 bottom seal.

### APPLICATIONS

Ideal for unit entry applications or anywhere that requires 60 minutes of fire resistance and an acoustic rating of 28 Rw.

### FEATURES

#### Acoustic Rating

- 28 Rw (28 STC)

#### Test Certificate number

- TL373(d)

#### Fire Resistance

- FRL -/60/30

#### Door Configuration

- Single leaf hung in steel or timber frame.

#### Perimeter Seal

- Raven RP47

#### Bottom Seal

- Raven RP99

#### Thickness

- 48mm (Nominal)

#### Size

- Maximum Size - 2400 x 1020 (-/60/30)

#### Hinges

- Minimum 3 steel hinges

#### Frame

- Pyropanel KDHW timber or packed pressed metal frame

#### Finish

- MDF as standard

### OPTIONAL EXTRAS

- Pre-hung in steel or timber frame
- Ply, Veneer, Steel or Laminate facings
- Vision panels - 300 x 200 or 250 x 250mm.
- Kick Panels of 1.2mm Stainless Steel to selected height
- Meets the BCA requirement for a smoke door.

### INSTALLATION

Door frame must be tightly sealed against wall structure using Pyropanel Multiflex or approved alternative fire and acoustic sealant. Metal door frames will require packing with Pyropanel FR board, Fire rated plaster, concrete or mortar to achieve desired acoustic rating.

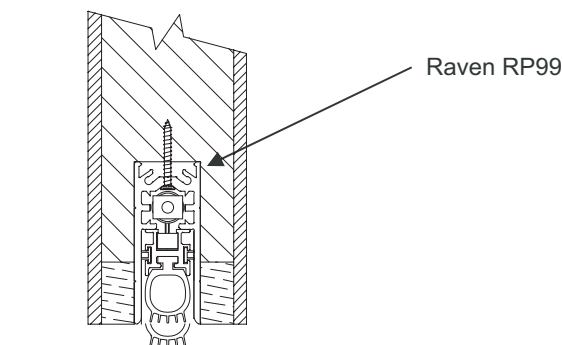
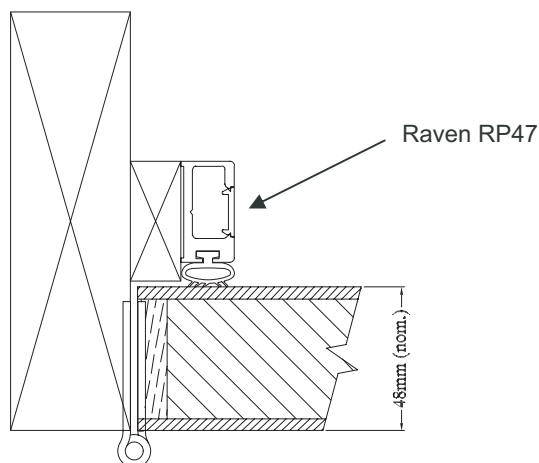

### HOW TO SPECIFY

*"Door to be a Pyropanel AS-28-PAN(ii) acoustic door with -/60/30\* FRL, installed into a Pyropanel Fire rated timber / packed metal\* door frame"*

\* denotes example—delete, change or specify as required



## UNITED DOORMAKERS

Melba Industrial Park, Factory 2,  
122-124 Beresford Road, Lilydale,  
Victoria 3140, Australia.

T: +61 3 9735 3911 F: +61 3 9735 5411

W: [www.udm.com.au](http://www.udm.com.au) E: [sales@udm.com.au](mailto:sales@udm.com.au)

Part of the

**PYRO PANEL**

Group