

# METAL CLAD DOORS

## UDM CLASSIC

### TECH SHEET – MC01

Issue: 12-05-06

**Metal Clad security door suitable for factories, garages and warehouses**

### DESCRIPTION

Pyropanel “UDM CLASSIC” Metal clad doors are a fully metal clad door with an integrated security lip.

### APPLICATIONS

UDM Metal Clad units are designed for installations into factories, warehouses, public buildings, shopping centers, showrooms, and can be used as external pedestrian access doors.

### FEATURES

- Standard sizes available Ex. Stock
- Standard finish zincanneal
- 3 screw fixed heavy duty hinges with backing plates
- BCA compliant UDM escape cylinder/lever as standard (other hardware available on request)
- Spring loaded restraining chain
- Preformed security lip

### OPTIONAL EXTRAS

- Special sizes available on request
- Vision Panels
- Vent grilles
- Door Closers
- Acoustic / dust seals
- Euroseal ® door frame
- 2-Pac paint finish
- Stainless Steel / Colorbond / Galvanised finishes
- Refer to Pyropanel door frame profile sheet for the full range of metal door frames

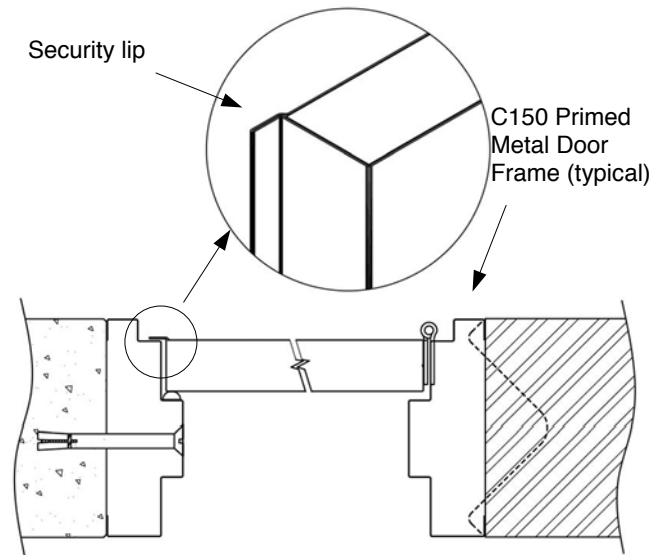
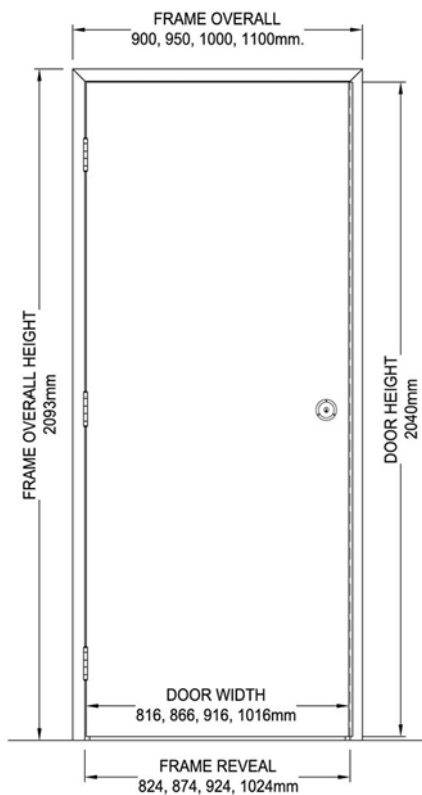

### STANDARD MODELS AVAILABLE

Model	Door size	Overall Frame Size
DMUH2322S	2040 x 816 x 36	2093 x 900
DMUH2332S	2040 x 864 x 36	2093 x 948
DMUH2342S	2040 x 916 x 36	2093 x 1000
DMUH2362S	2040 x 1016 x 36	2093 x 1100

### HOW TO SPECIFY

Eg: “Door to be ‘Pyropanel UDM Classic Metal Clad’ Model DMU2322S\*, factory hung in C150\* profile Primed Metal Door Frame (PMDF) including UDM Lockset, restraining chain and 3 No. fixed pin 100 x 75 x 2.5 hinges”.

\* denotes example only, delete or change as required.



## UNITED DOORMAKERS

Melba Industrial Park, Factory 2,  
122-124 Beresford Road, Lilydale,  
Victoria 3140, Australia.

T: +61 3 9735 3911 F: +61 3 9735 5411

W: www.udm.com.au E: sales@udm.com.au

Part of the

